

REVISIONS				
REV	ECN	DATE	DESCRIPTION	ISSUER
A	EC-00852	4/23/2019	RELEASE	RML

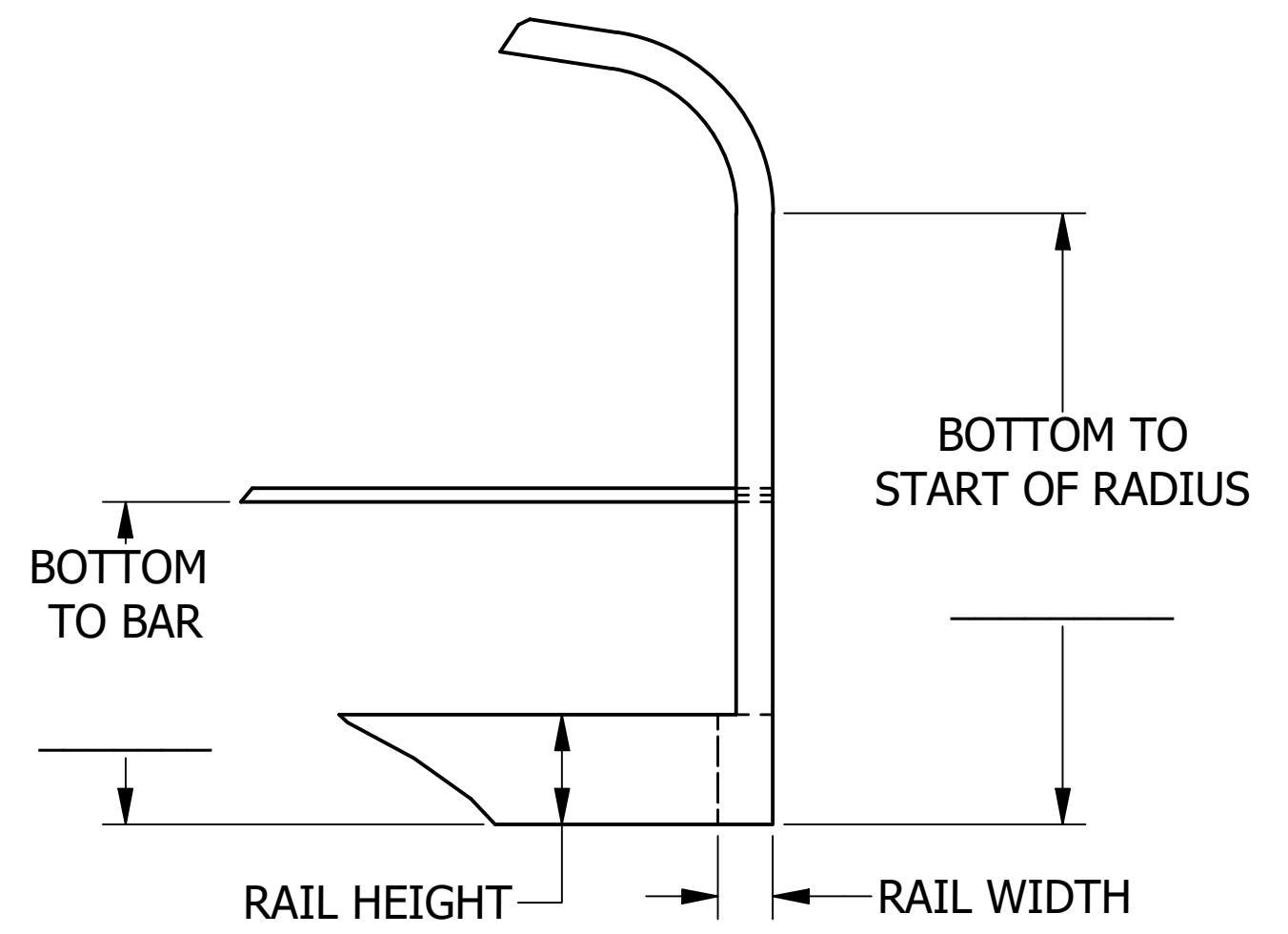

ATTACHMENT METHOD(S)

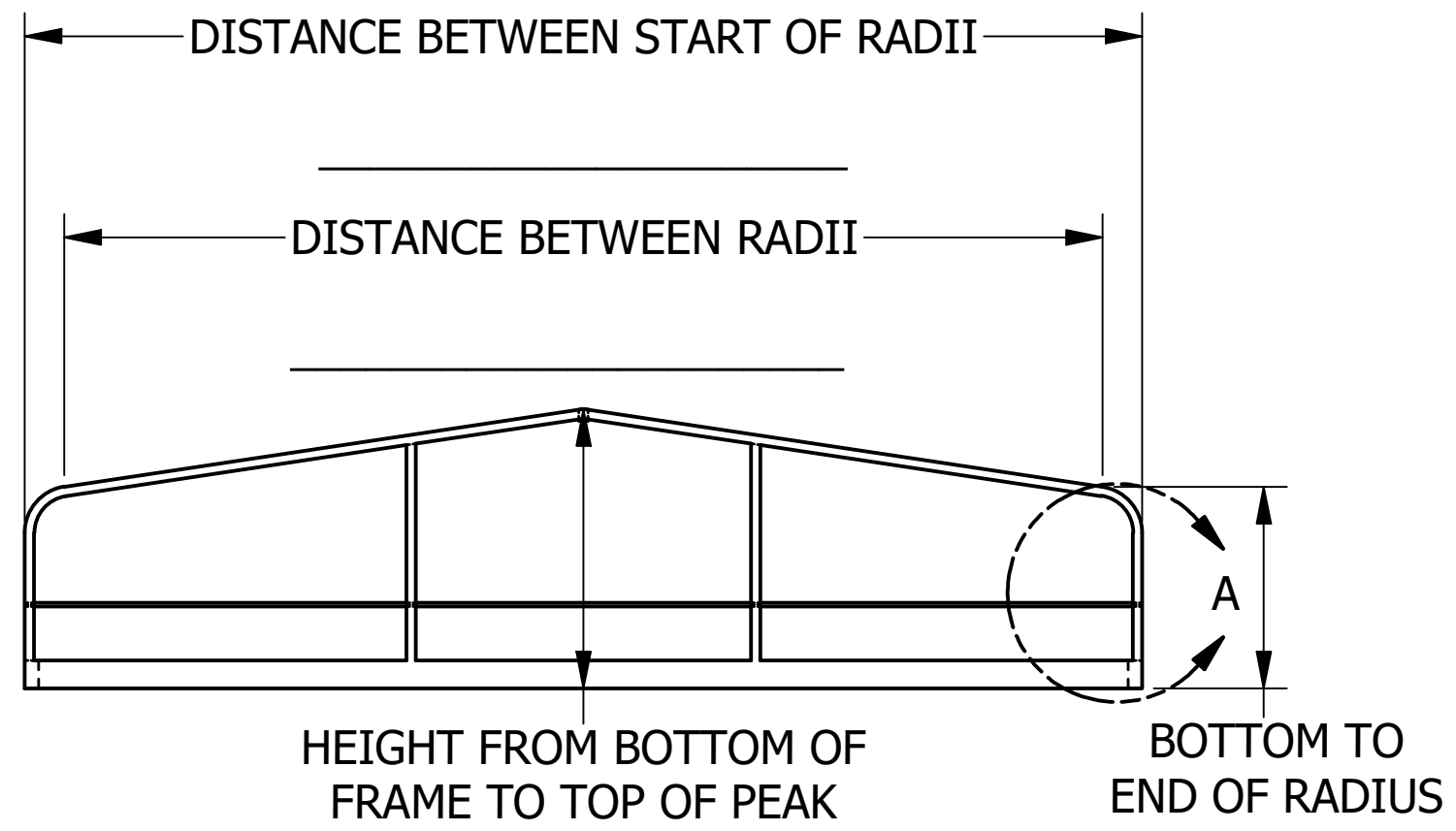
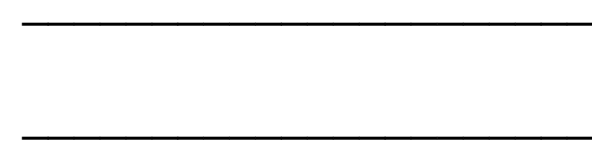

DETAIL A

TOTAL NUMBER OF BOWS

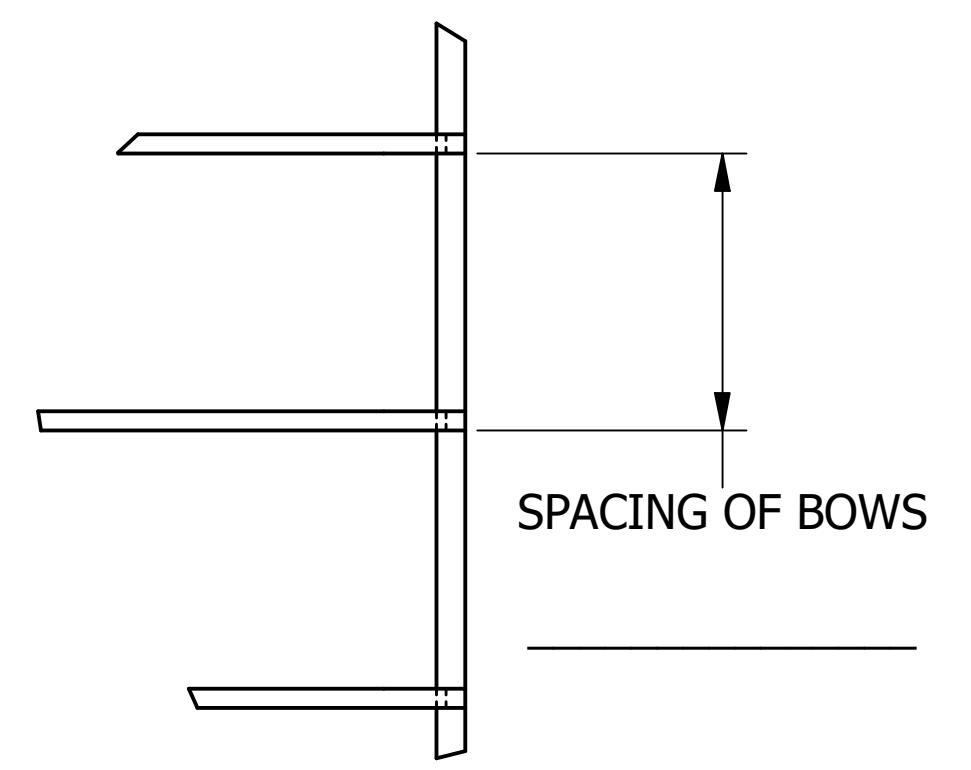
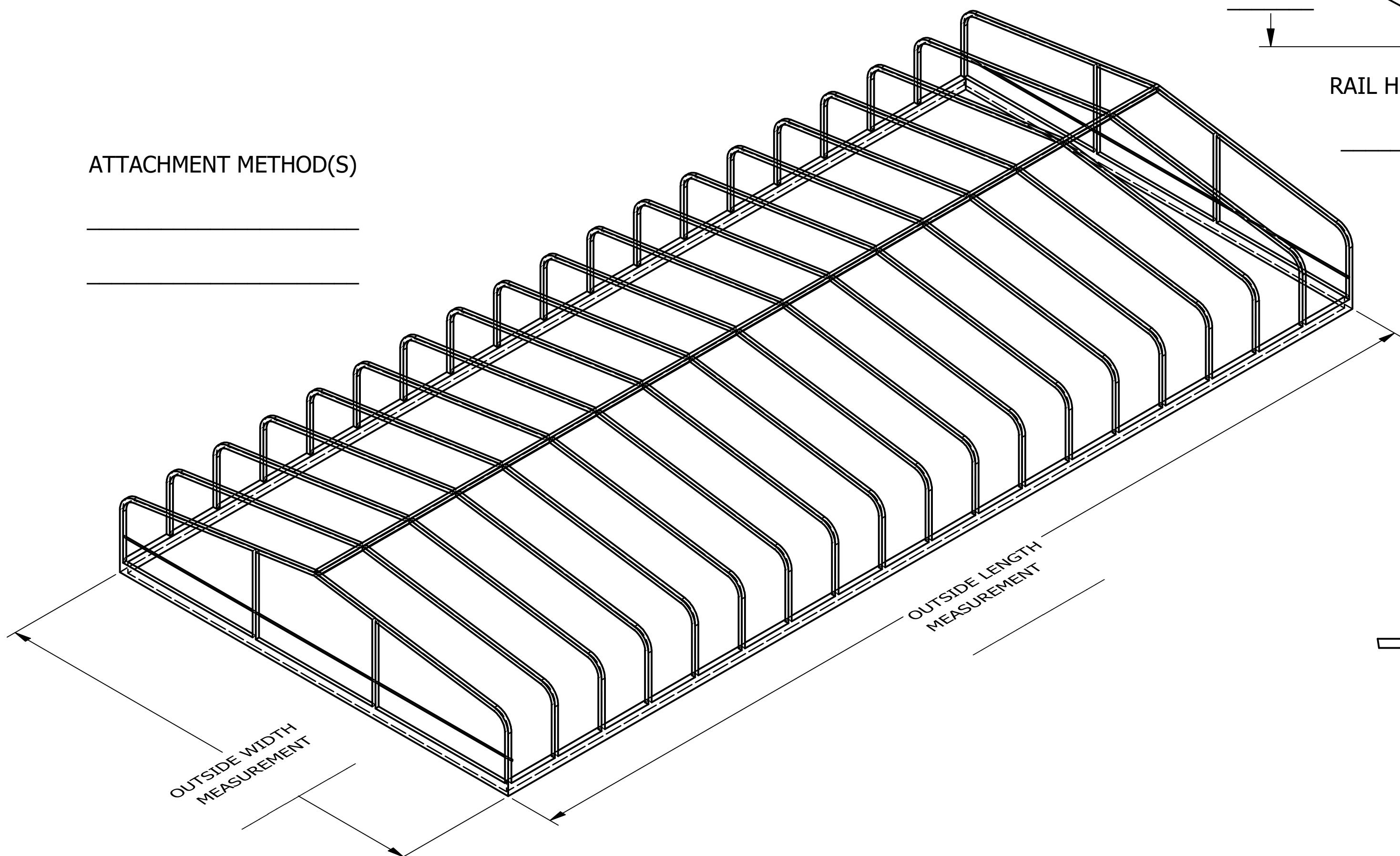
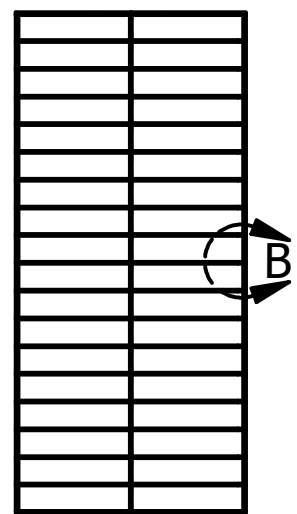

DETAIL B

TOLERANCES - UNLESS NOTED  
 DECIMAL ±  
 FRACTION ±  
 ANGLE ±



1314 Walnut St. - Springfield, SD 57062 605-369-6000

TITLE:

**CRAFTLANDER HIGH TOP FRAME DETAIL SHEET**

SIZE

**C**

DRFT: **robert.lambert**  
 ENGR: **CRH**

DATE **4/23/2019**  
 DATE **4/23/2019**

SCALE

SHEET **1**  
 1

PART NO:

**F-170**

**NOTICE** THIS ILLUSTRATION IS THE PROPERTY OF RUSH-CO, AND MUST NOT BE USED IN ANY WAY DETRIMENTAL TO RUSH-CO'S INTERESTS.